

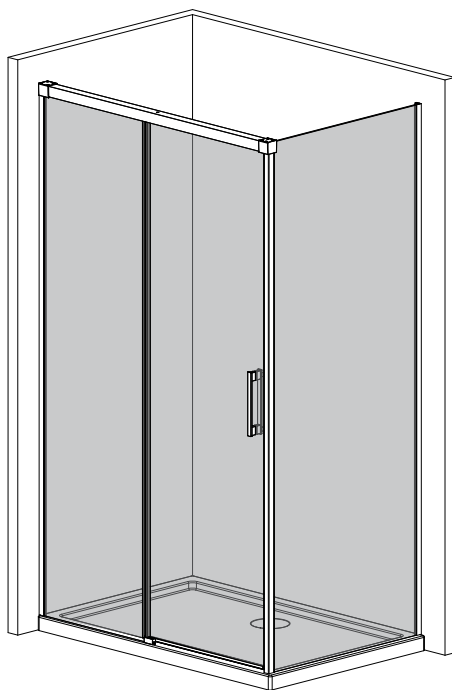









- | | | | |
|--|----------------------|---|-------------------------|
|  PL | Instrukcja montażu |  CZ | Pokyny k instalaci |
|  GB | Assembly instruction |  RUS | Инструкция по установке |
|  D | Montageanleitung |  UA | Інструкція по установці |
|  SK | Návod na inštaláciu |  H | Szerelési útmutató |
| | |  RO | Instructiuni de montaj |



Idea KDJ

-  PL Instrukcja pokazuje montaż kabiny w wariante lewym
-  GB Assembling instruction shows installation of left-side version
-  D Die Montageanleitung stellt die linke Variante der Dusche dar
-  SK Návod na inštaláciu sa vzťahuje na ľavé prevedenie
-  CZ Návod zobrazuje instalaci sprchového koutu vlevo
-  RUS В инструкции указан монтаж левого варианта кабины
-  UA В інструкції вказаний монтаж лівого варіанту kabini
-  H A szerelési útmutató balos verzióra vonatkozik
-  RO Instrucțiunile de montaj se refera la instalarea cu deschidere pe stanga

Požiadavky a rady pre inštaláciu

2+1rok**ZÁRUKA**

Doporučujeme montáž naším servisným technikom, ktorý Vám predĺži záruku (2+1 rok)

Objednávka montáže: info@hidrotrend.sk | radaway.sk

Radaway servisný technici sú zárukou:

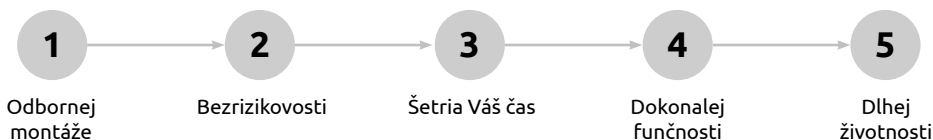

Predtým ako si začnete sami inštalovať sprchovací kút si pozorne prečítajte nasledovné pokyny.

1. Pred začatím montáže skontrolujte výrobok či nieje poškodený, nevykazuje žiadne vady spôsobené prepravou.
2. Určite skontrolujte, či daný výrobok zodpovedá rozmerom, farbou ako aj objednávacím kódom Vami objedného výrobku.
3. Po zabudovaní výrobca uznáva záruku len na výrobné vady a vady materiálu. Za rozdiely zistené po namontovaní nenesieme zodpovednosť.
4. Výrobok používajte výhradne podľa jeho určenia, v opačnom prípade záruka zaniká.
5. Silikónom utesnený výrobok je možné začať používať 24 hodín po namontovaní.
6. Vyhradujeme si právo na konštrukčné zmeny výrobkov.
7. Doporučenie: k inštalácii výrobku sú potrebné dve osoby.

Na sprchovacie kúty a vaničky poskytujeme základnú záruku 2 roky.

Záruka začína plynúť dňom predaja výrobku uvedenom na doklade o kúpe výrobku. Záruku si môžete uplatniť u svojho predajcu.







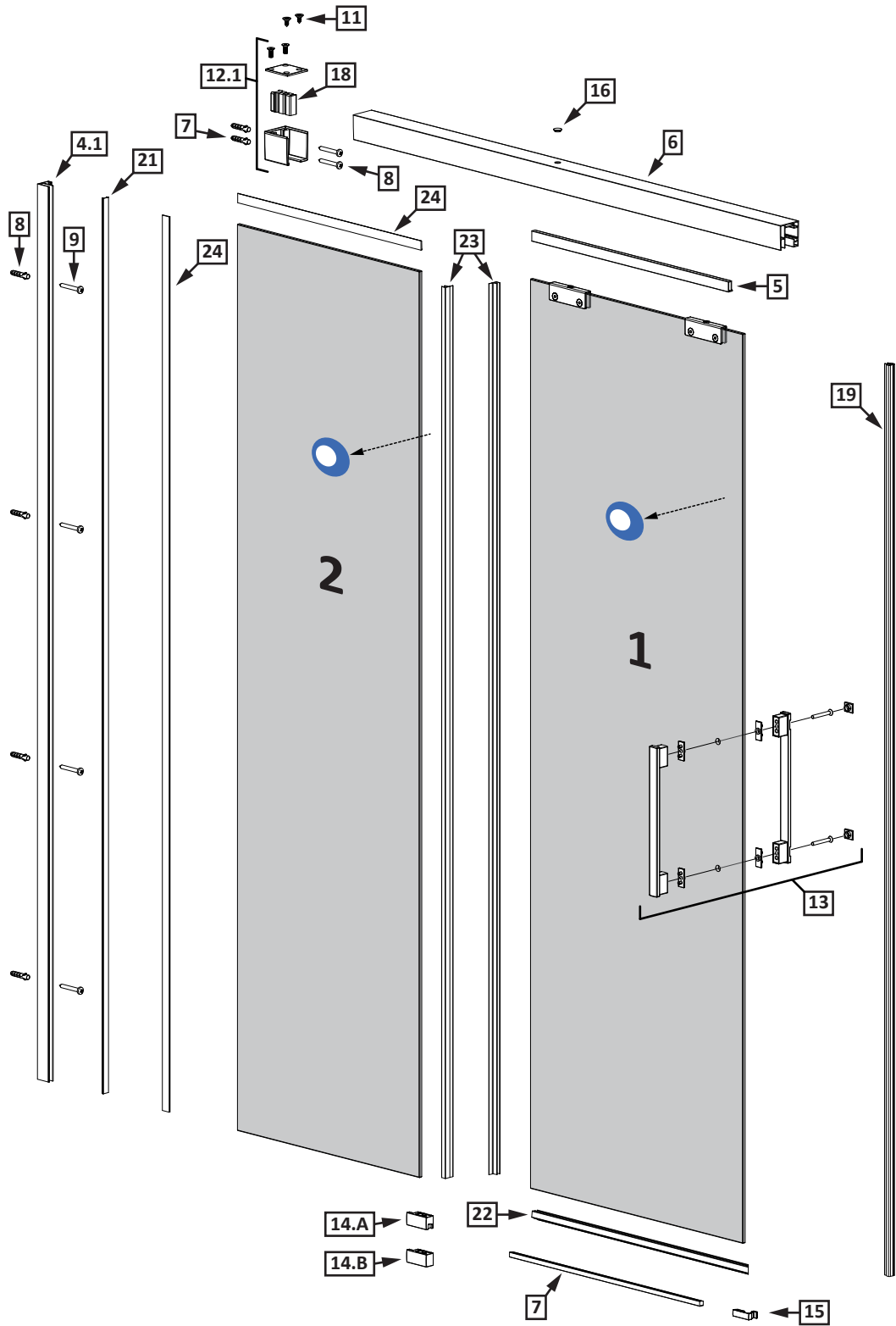

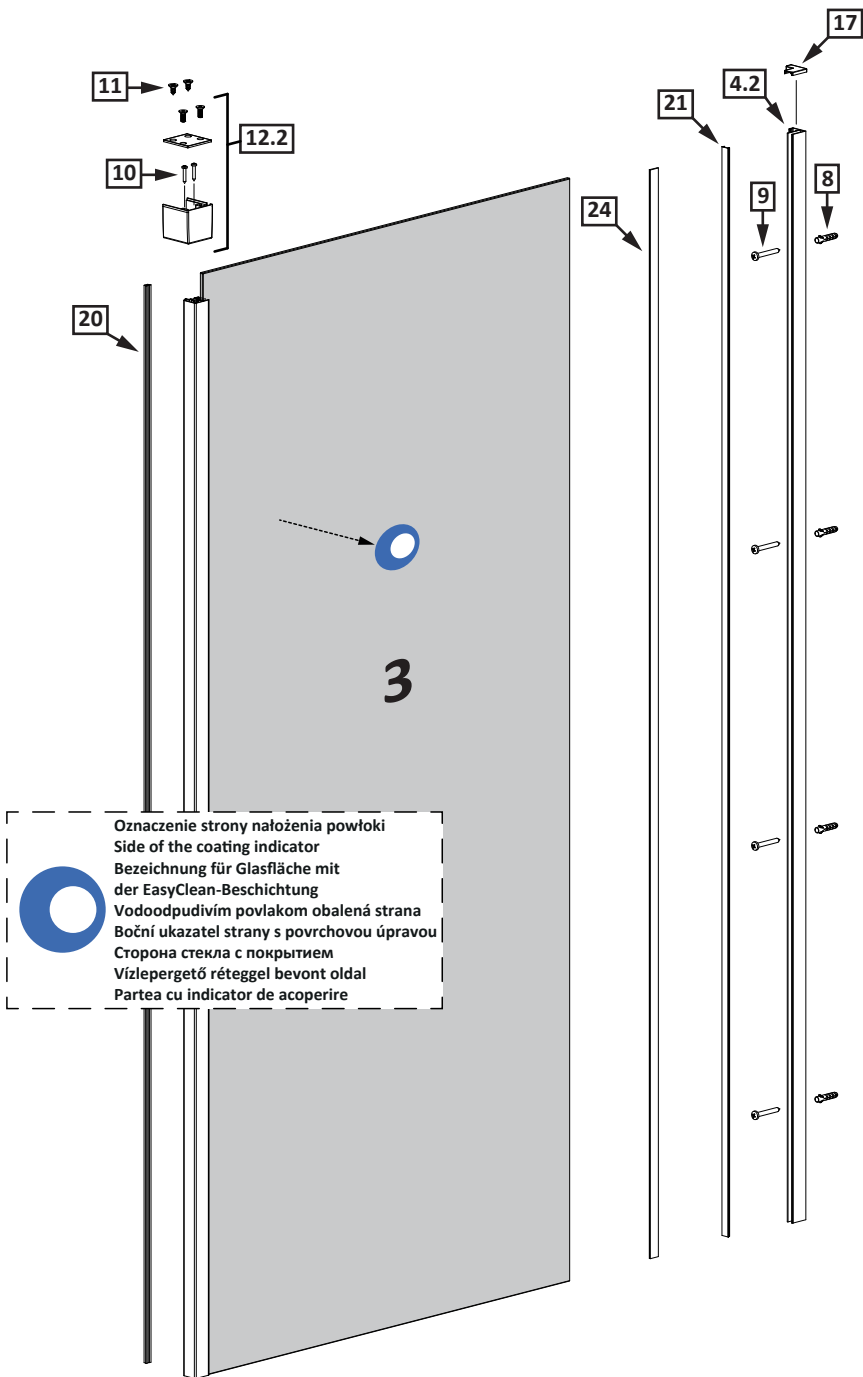

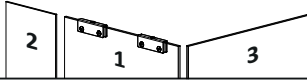



Jednou s podmienok záruky je aj odborná montáž podľa aktuálneho návodu na montáž. Na nesprávnu a neodbornú montáž sa záruka nevzťahuje. Odstraňovanie závad spôsobených neodbornou montážou, prípadné búracie práce, prepravné náklady s tým spojené sú náklady kupujúceho. Na mechanické poškodenie skla sa záruka nevzťahuje.

V prípade montáže výrobku servisným technikom Radaway sa záruka predlžuje na 2+1 rok.

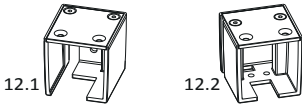
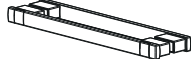



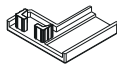



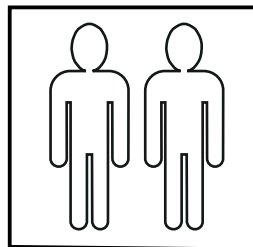
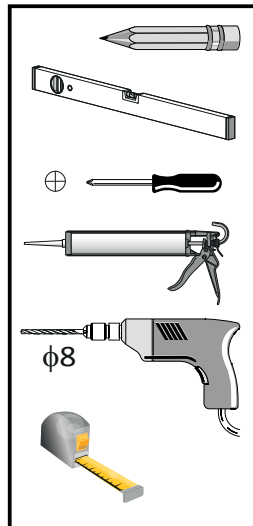

Záručné podmienky nájdete na záručnom liste.



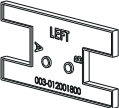
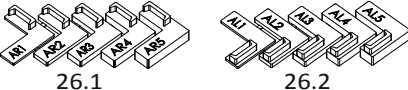
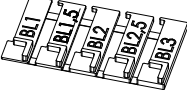
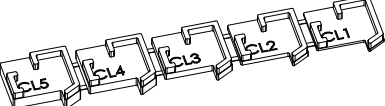
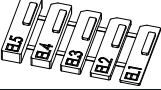

Nr Nr No. číslo počet № Sorszám Numar	Oznaczenie Mark Bezeichnung Označenje Označení обозначение Jelölés Componenta	Sztuk Pcs. Stück Kus KS штук Db. Bucati
1. 2. 3.		1 1 1
4.1 4.2		1 1
5.		1
6.		1
7.		1
8.	 $\phi 8$ DIN 7981	10
9.	 5x40 DIN 7991	10
10.	 3.5x25 DIN 7991	2
11.	 ST4.2x9.5 DIN 7982	4
12.1 12.2		1 1
13.		1
14.A		1
14.B		1
15.		1
16.		1
17.		1
18.		1



Nr Nr No. číslo počet № Sorszám Numar	Oznaczenie Mark Bezeichnung Označenje Označení обозначение Jelölés Componenta	Sztuk Pcs. Stück Kus KS штук Db. Bucati
19.		1
20.		1
21.		2
22.		1
23.		2
24.	 L = 5000mm	1
25.		1
26.1 26.2		1 1
27.		1
28.		1
29.		1
30.		4
31.		4
32.1 32.2		1 1
33.	 ϕ 2,8	1

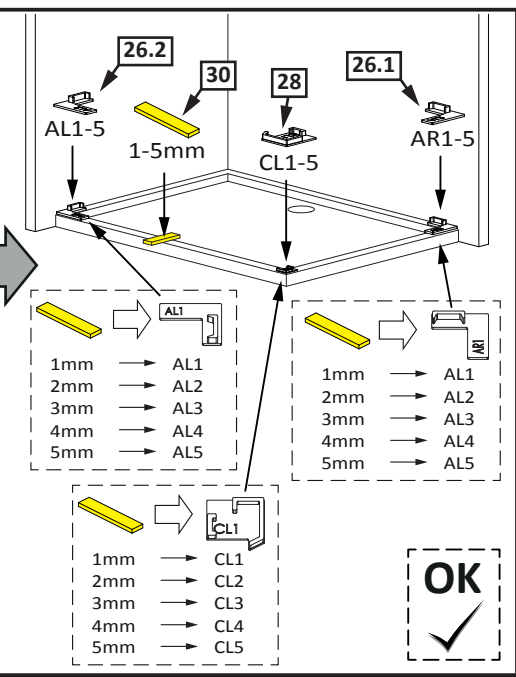
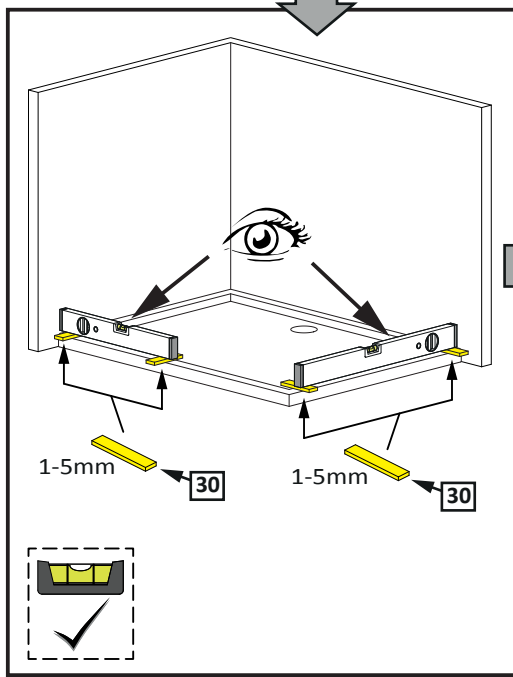
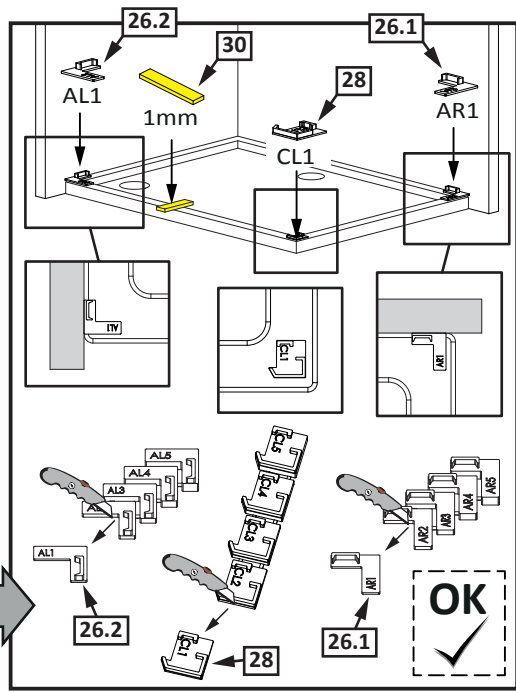
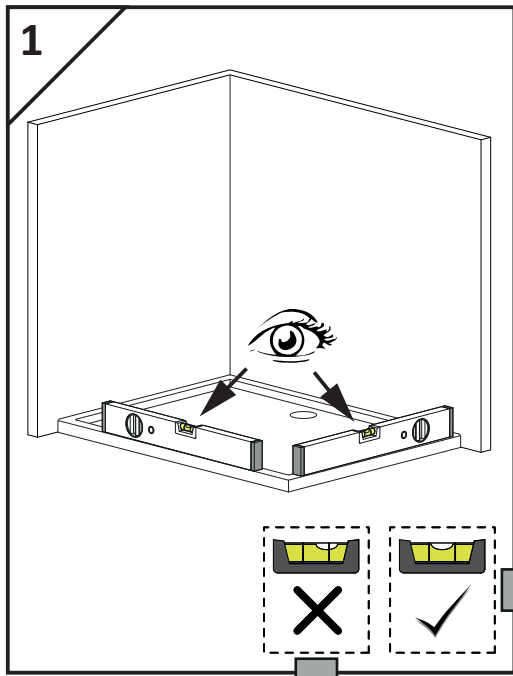

2

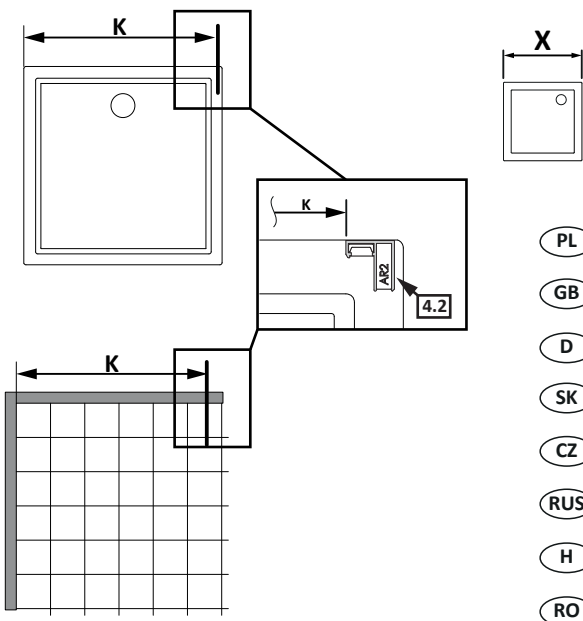

X	1000	1100	1200
K	966*	1066*	1166*

X	1300	1400	1500	1600
K	1266*	1366*	1466*	1566*

- PL** * Wymiary dotyczą montażu typowej kabiny montowanej na brodziku
- GB** * All dimensions refer to installation on shower tray
- D** * Die Masse betrifft standard Dusche, die auf der Duschwanne montiert ist
- SK** * Všetky miery platia pri osadení sprchovej vaničky
- CZ** * Montážní rozměry se vztahují k instalaci na sprchové vaničky
- RUS** * Размеры касаются монтажа стандартной кабины на поддоне
- H** * Az összes méret zuhanytálcára történő építés esetén érvényes
- RO** * Toate dimensiunile se referă la instalarea pe cădița de duș

3

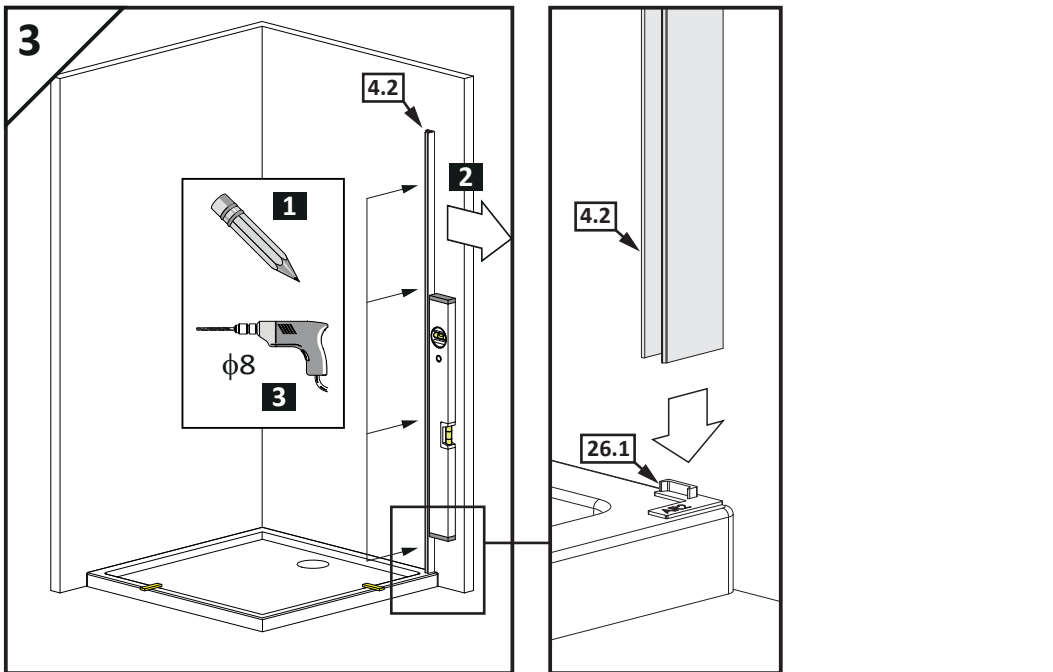

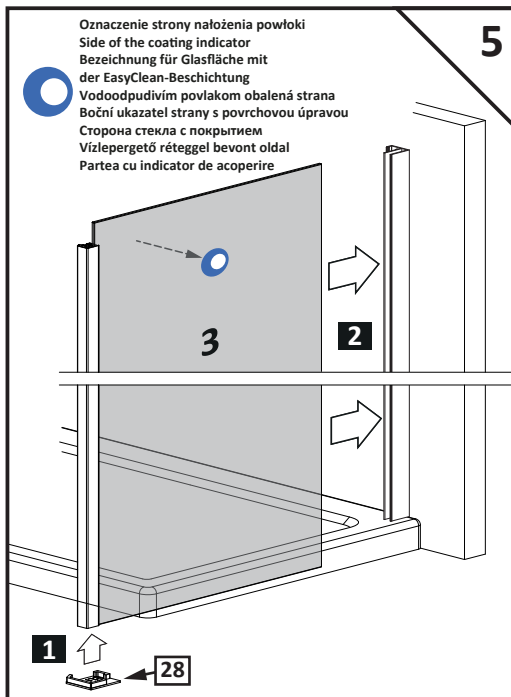
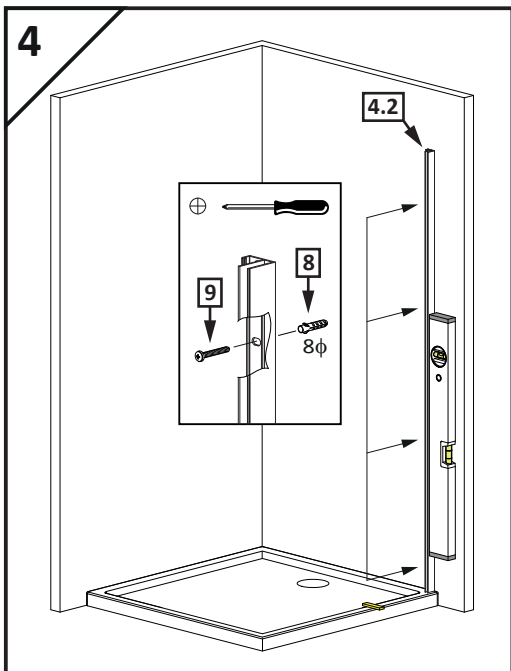

5.1

(PL) * Wymiary dotyczą montażu typowej kabiny montowanej na brodziku
 (GB) * All dimensions refer to installation on shower tray
 (D) * Die Masse betrifft standard Dusche, die auf der Duschwanne montiert ist
 (SK) * Všetky miery platia pri osadení sprchovej vaničky
 (CZ) * Montážní rozměry se vztahují k instalaci na sprchové vaničky
 (RUS) * Размеры касаются монтажа стандартной кабины на поддоне
 (H) * Az összes méret zuhanytálcára történő építés esetén érvényes
 (RO) * Toate dimensiunile se referă la instalarea pe cădița de duș

Y	750	800	900	1000	1100	1200
N	~737*	~787*	~887*	~987*	~1087*	~1187*

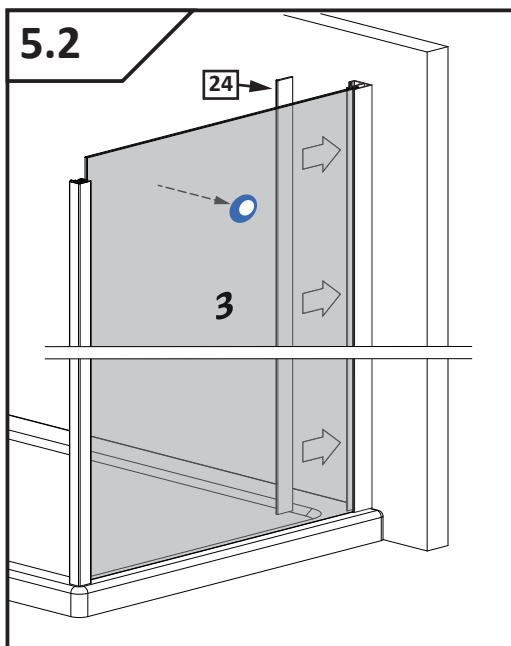

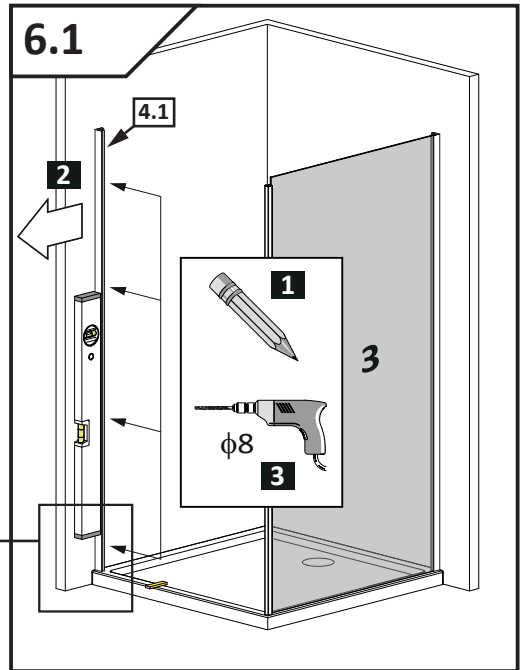
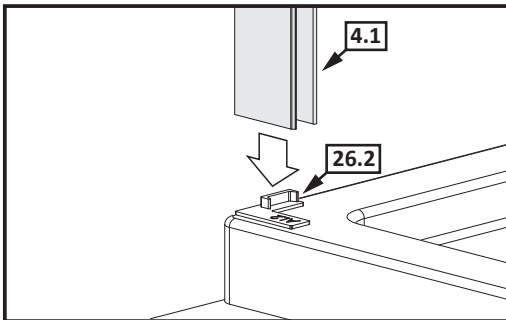
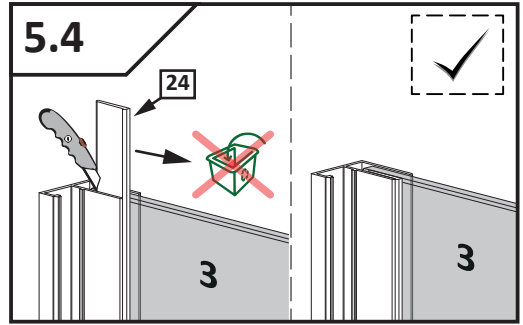
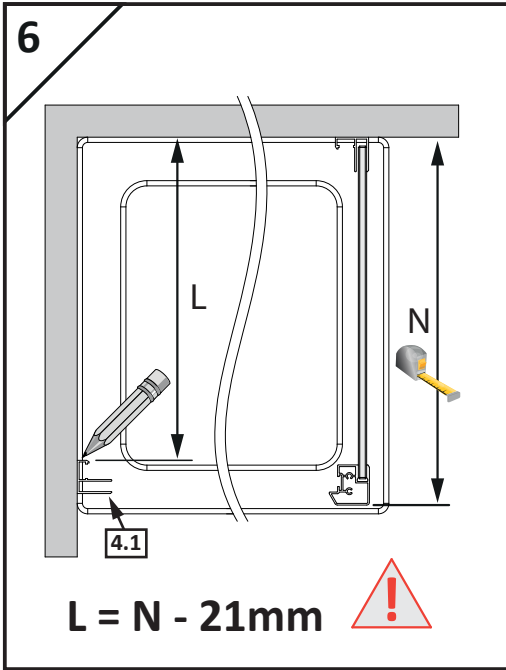
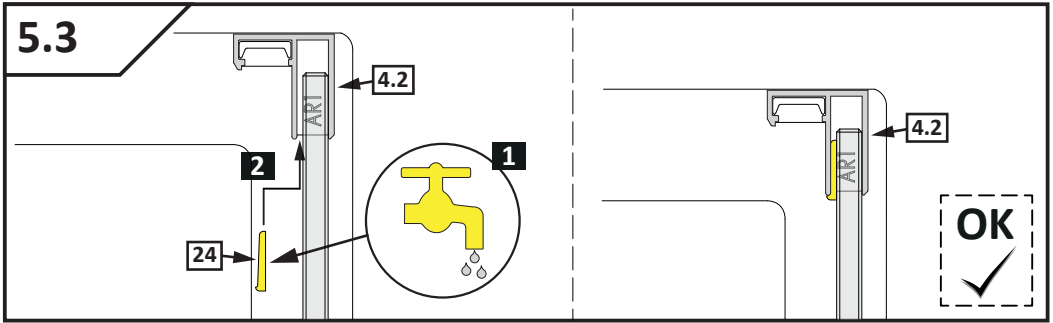

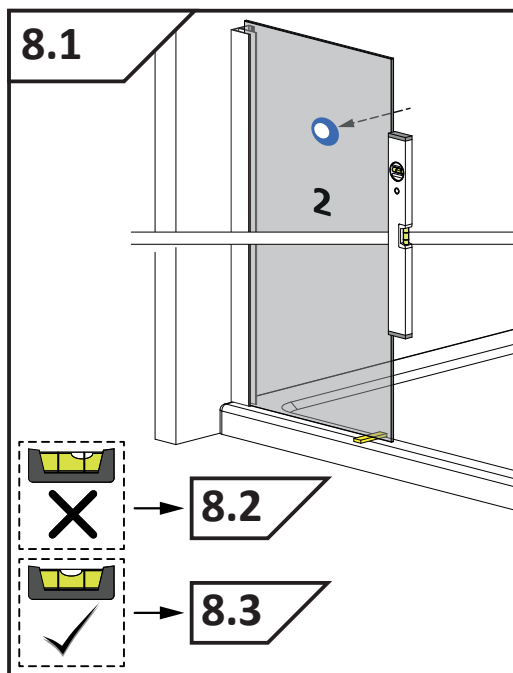
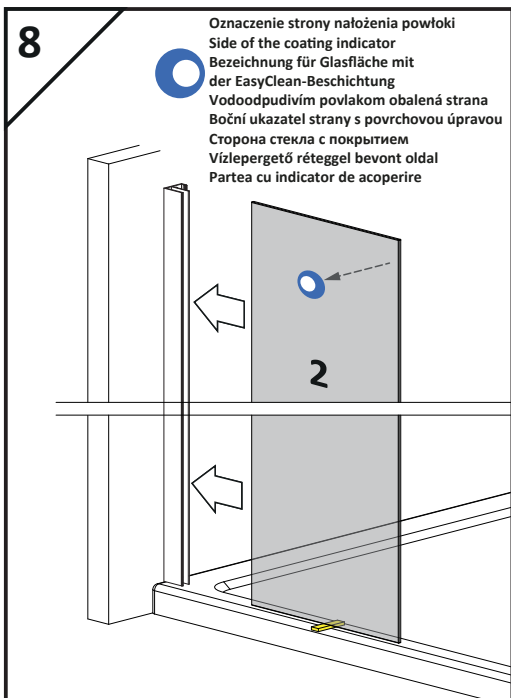
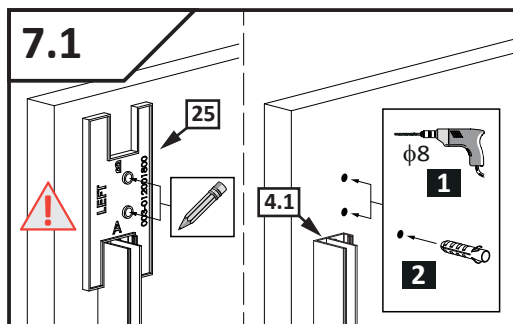
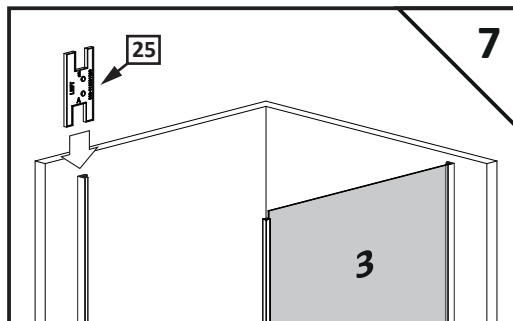
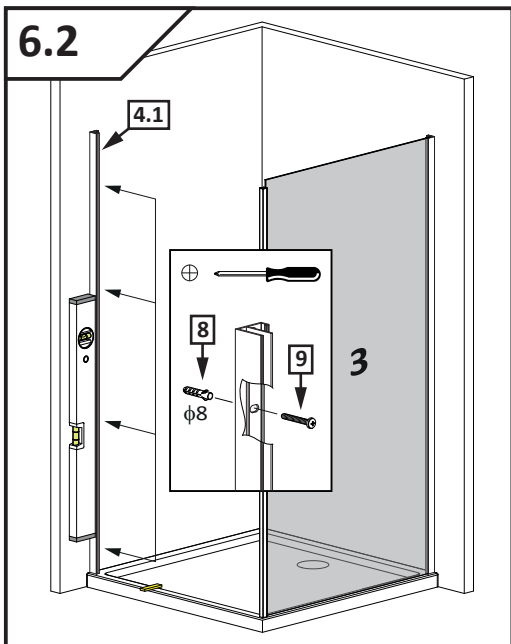

8.2

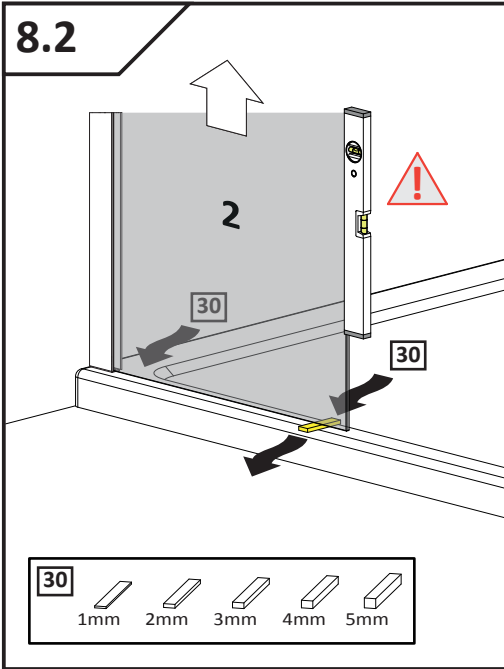

8.3

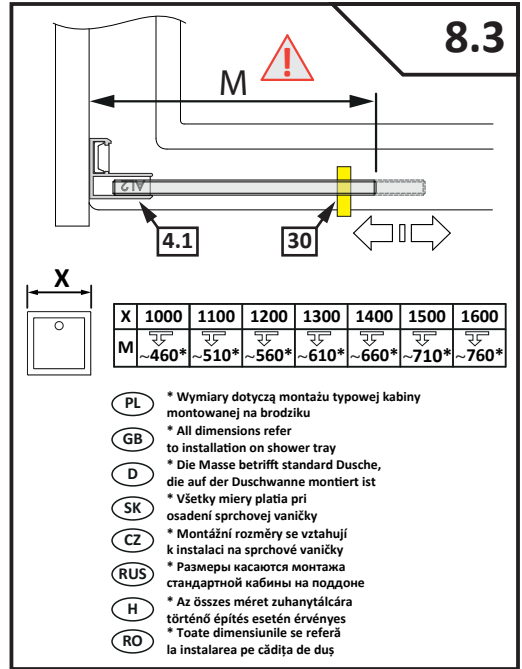

8.4

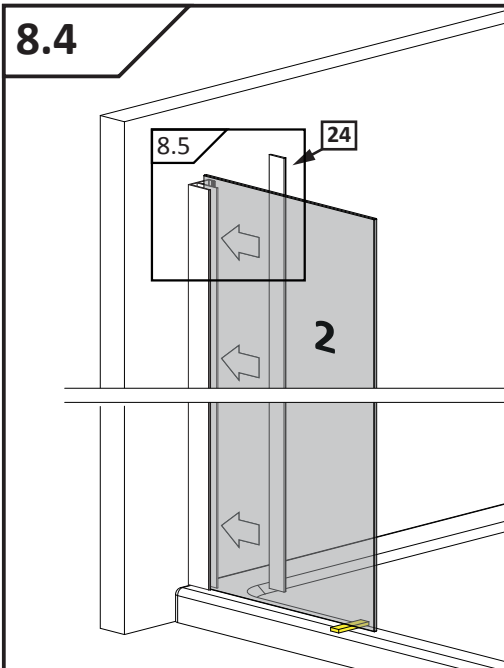

8.5

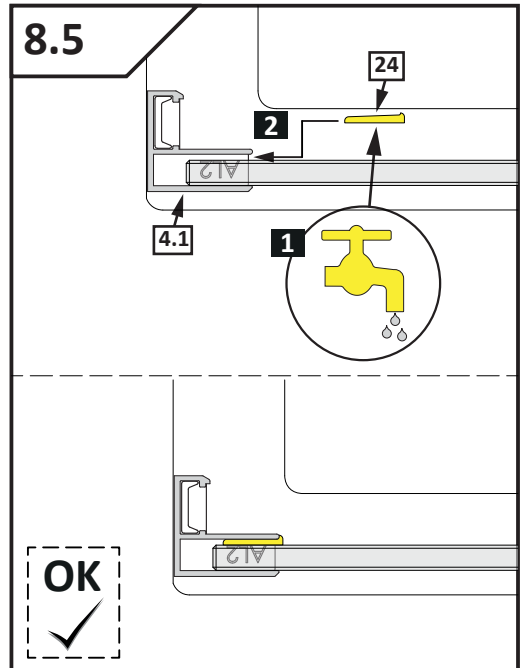

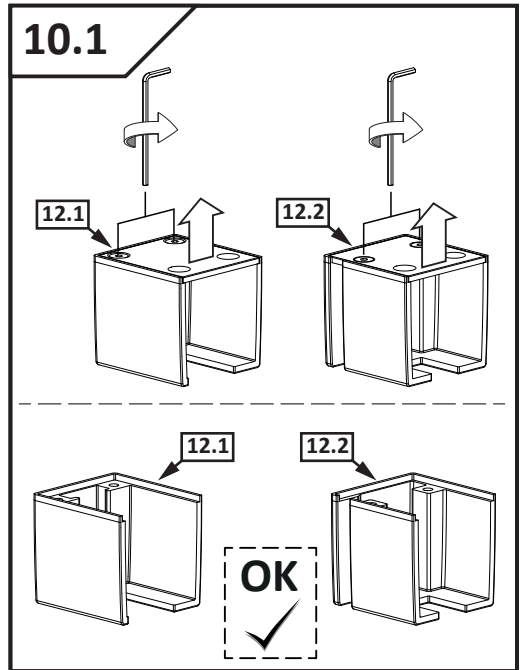
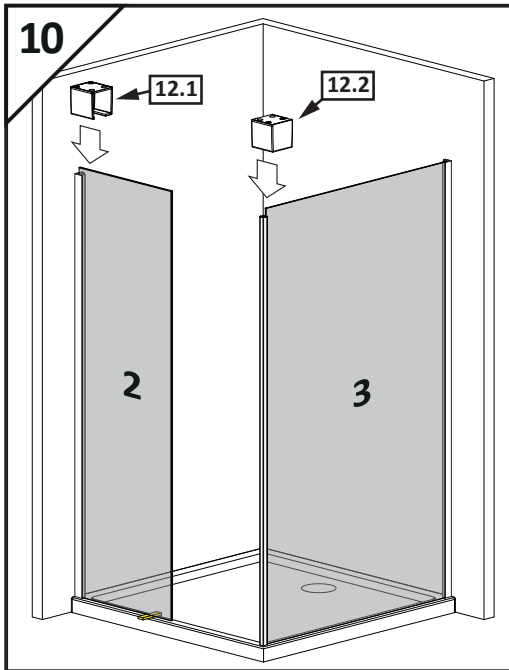
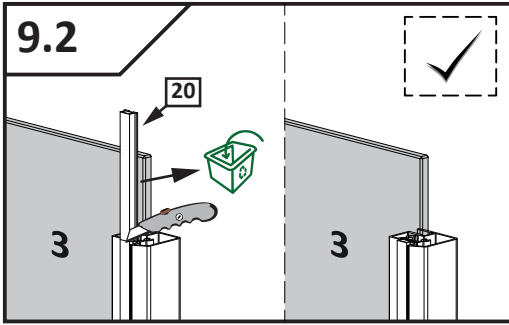
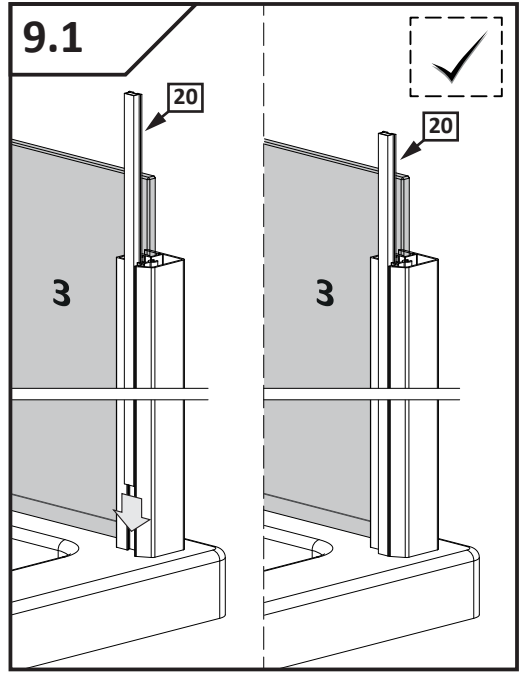
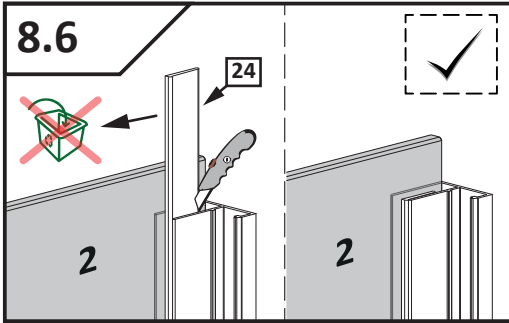

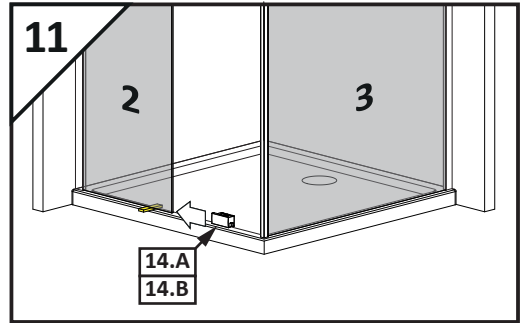
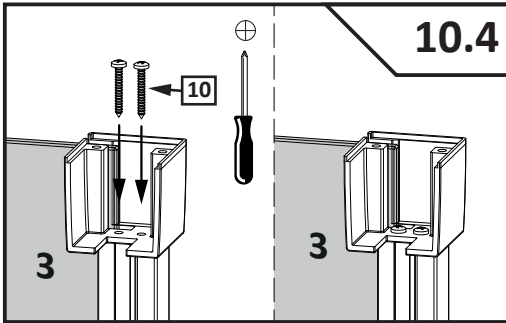
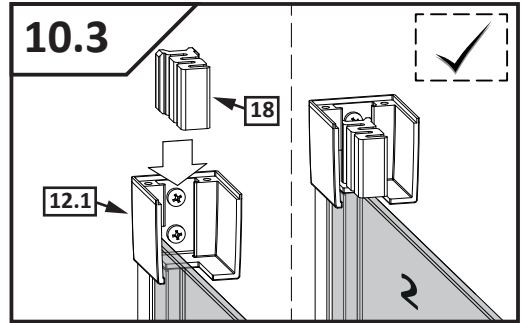
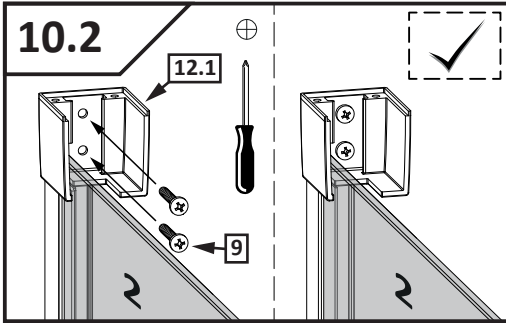

Montaż z listwą progową
Installation with threshold profile
Die Montage mit Schwalleiste
Montovanie s prahovým profilom
Instalace přechodové lišty
Монтаж с профилем порога
Szerelés küszöb profillal
Instalarea cu profil prag

 **....A**

Montaż bez listwy progowej
Installation without threshold profile
Die Montage ohne Schwalleiste
Montovanie bez prahového profilu
Instalace bez prahové lišty
Монтаж без профиля порога
Szerelés küszöb profil nélkül
Instalarea fara profil prag

 **....B**

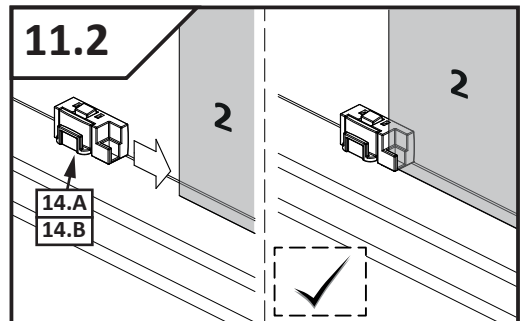
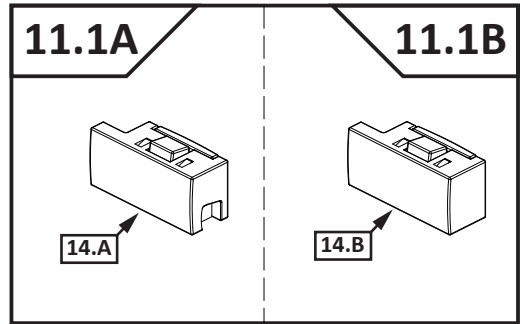

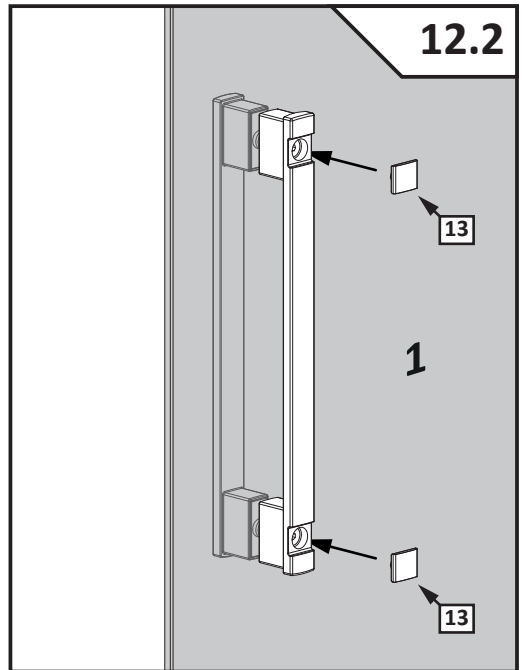
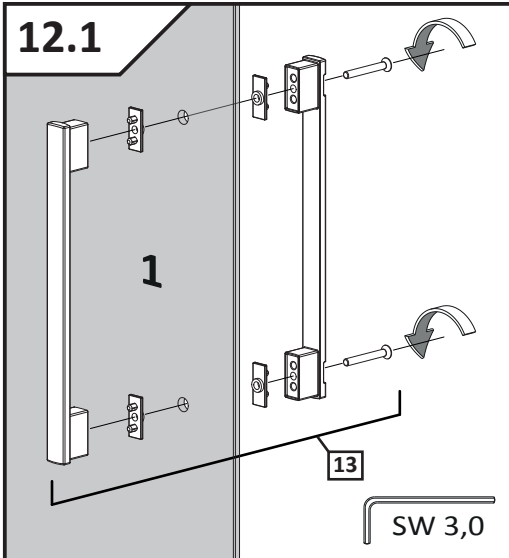
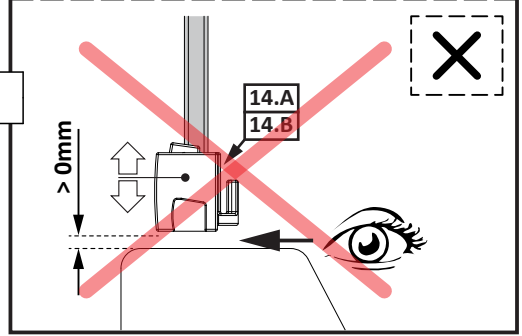
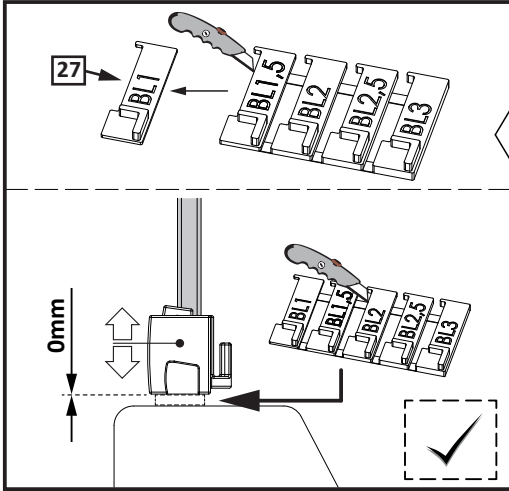
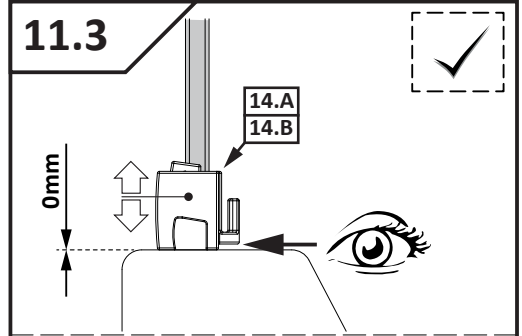
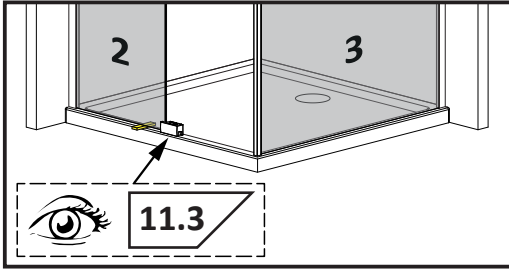

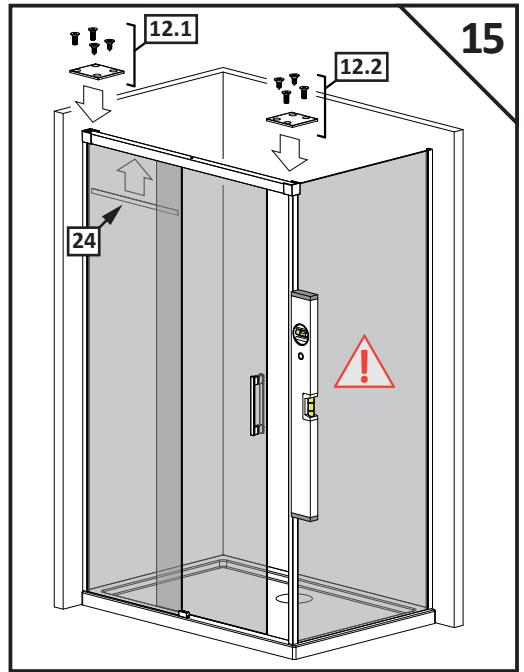
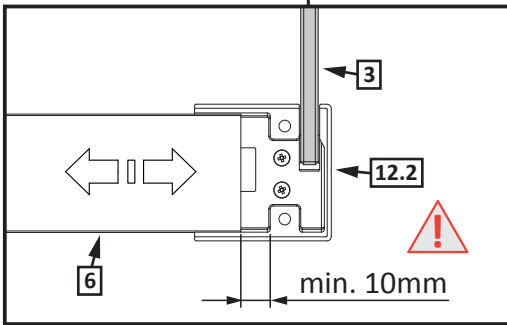
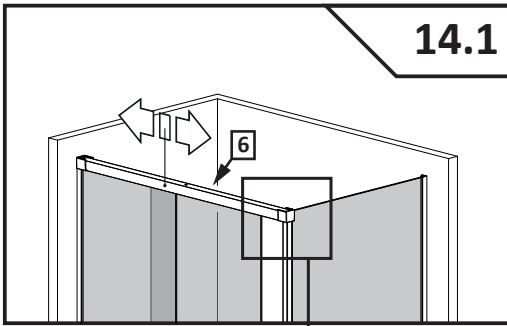
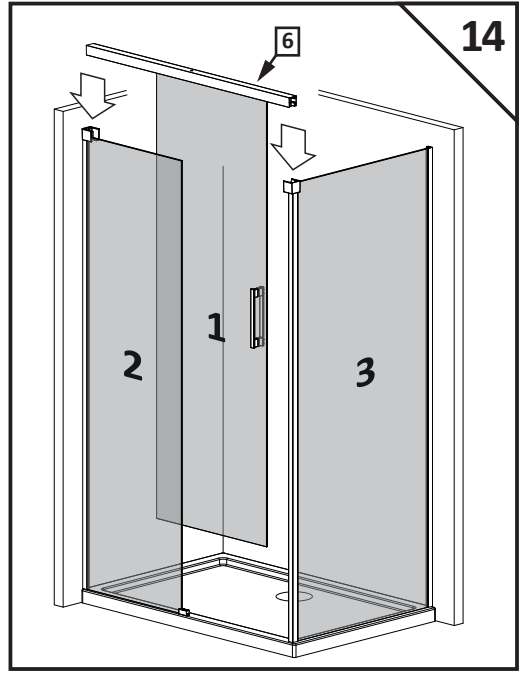
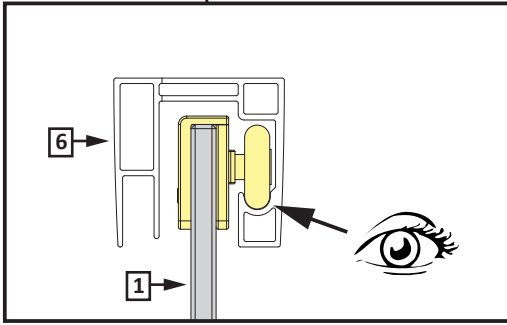
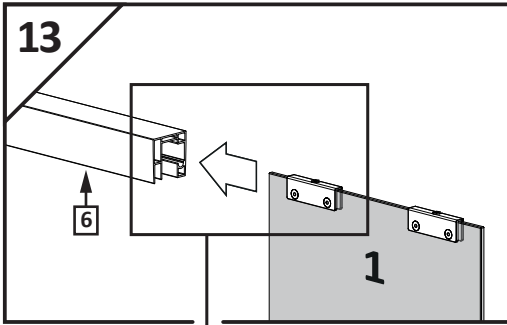

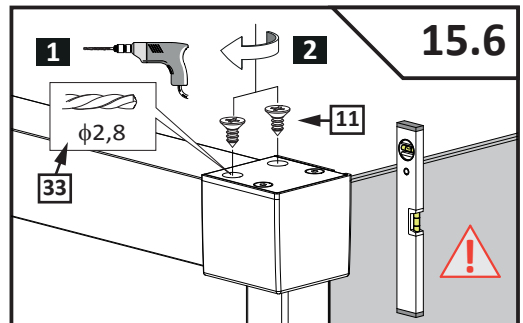
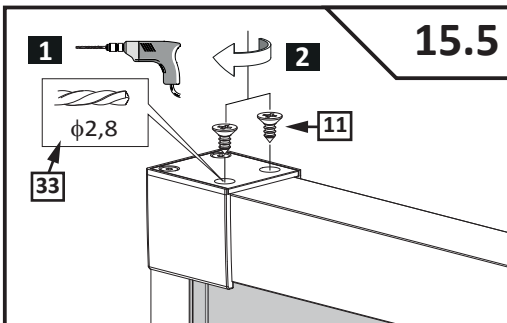
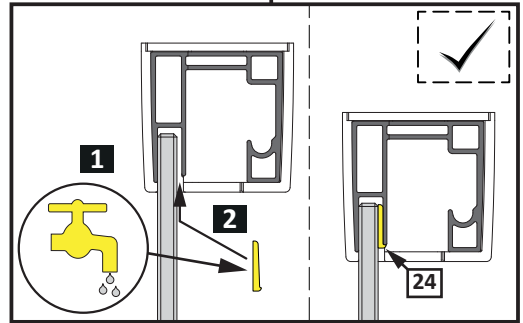
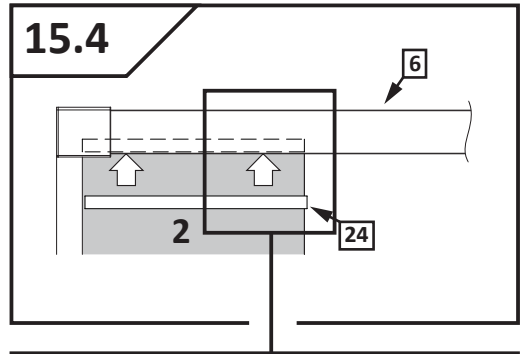
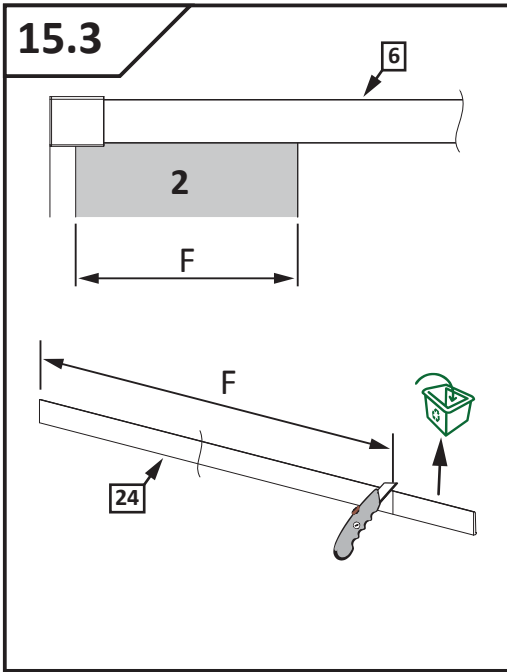
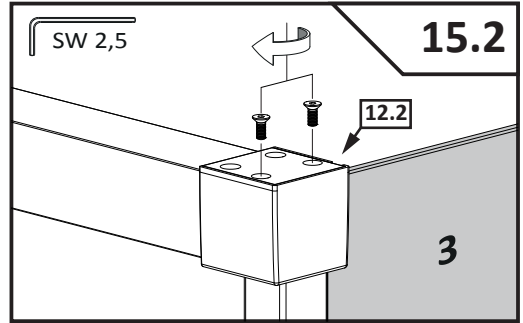
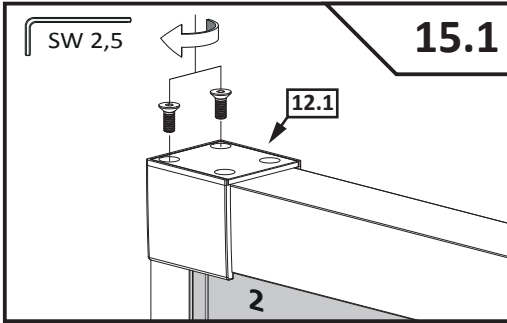

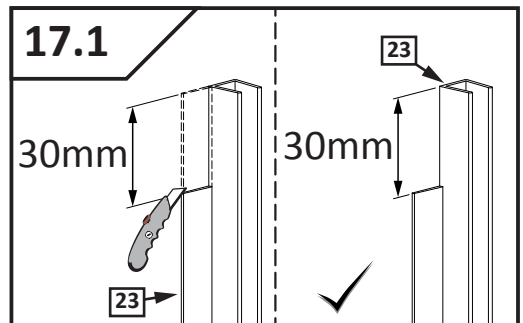
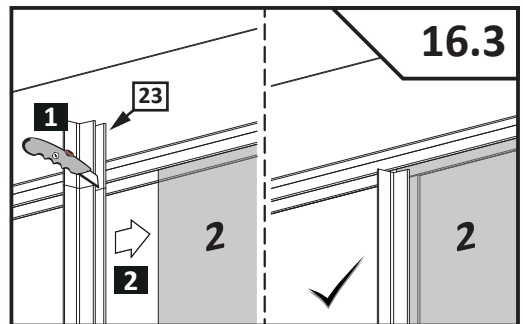
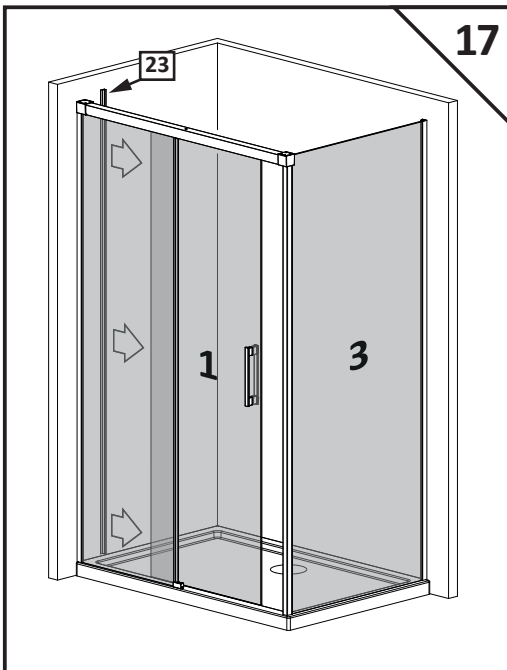
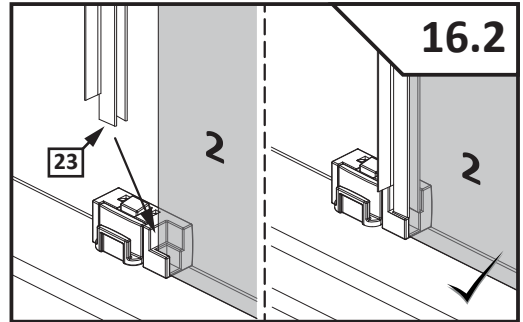
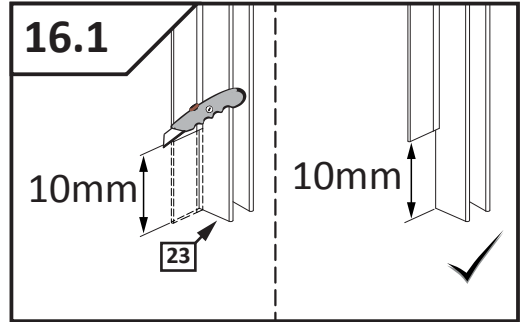
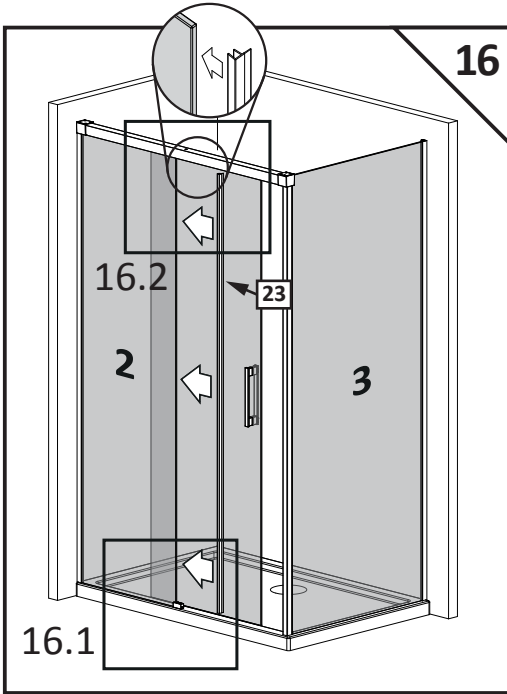

17.2

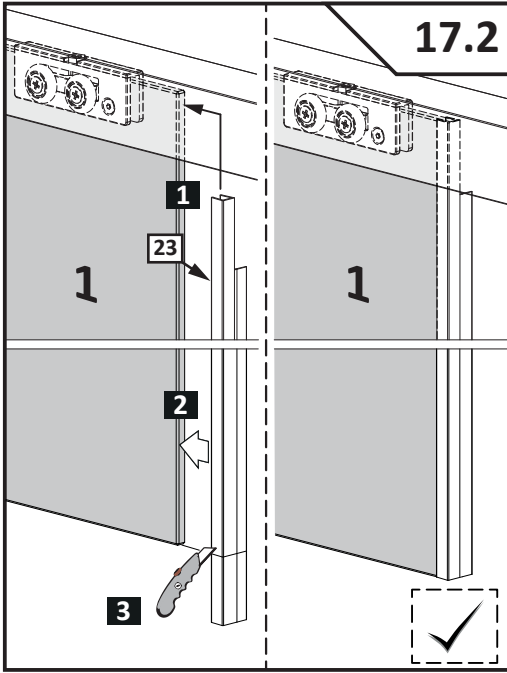

18

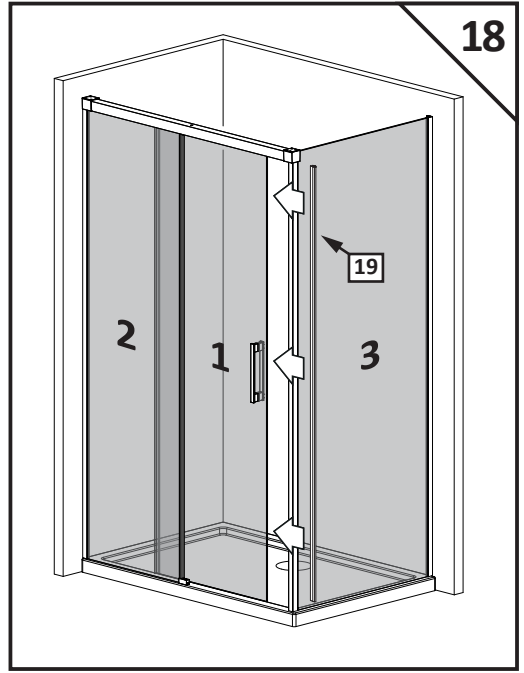

18.1

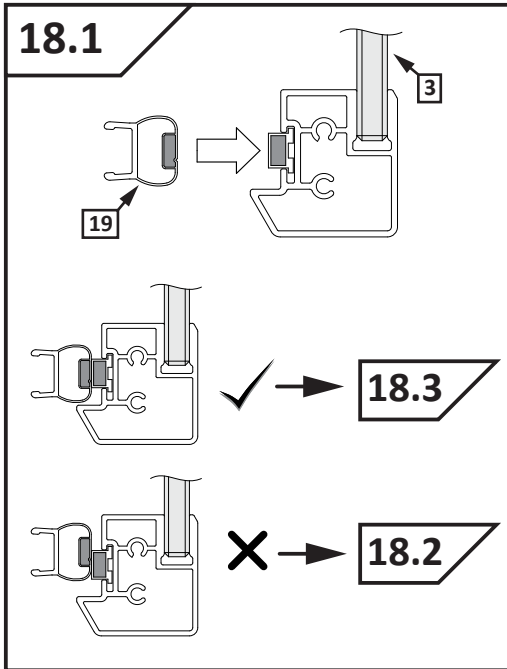

18.2

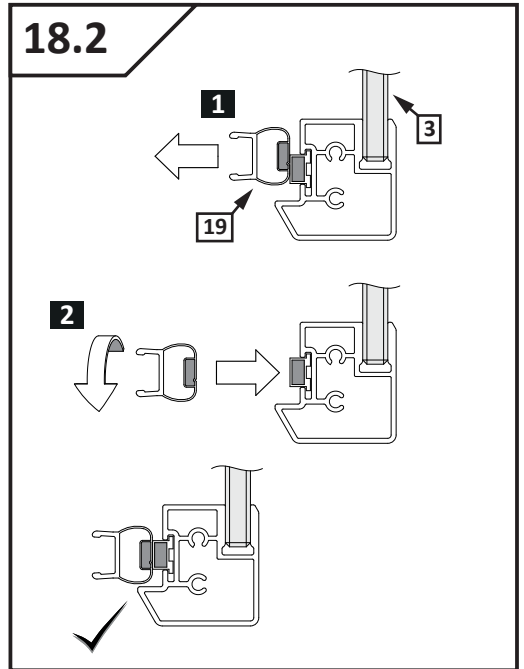

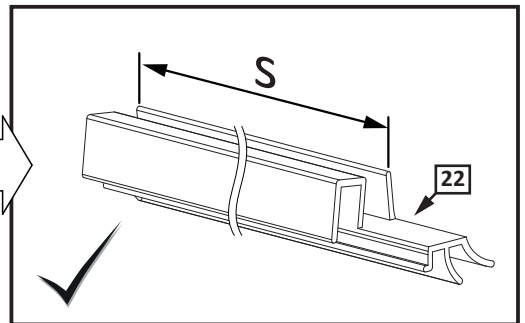
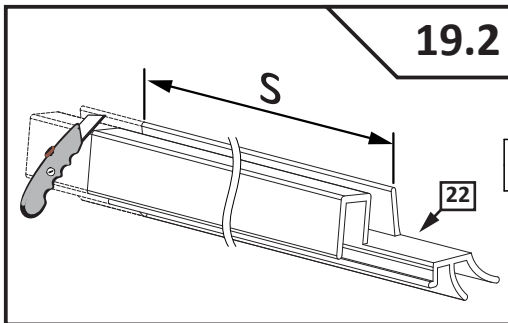
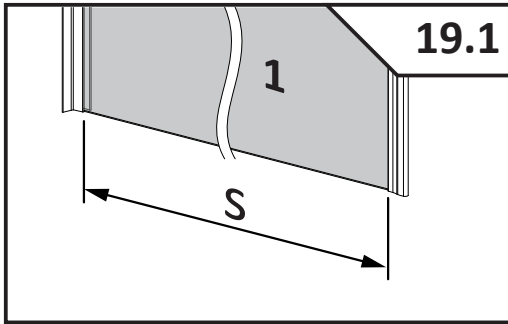
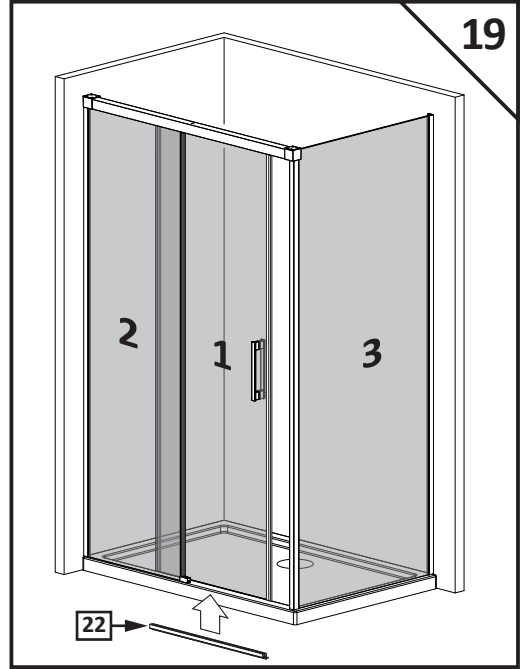
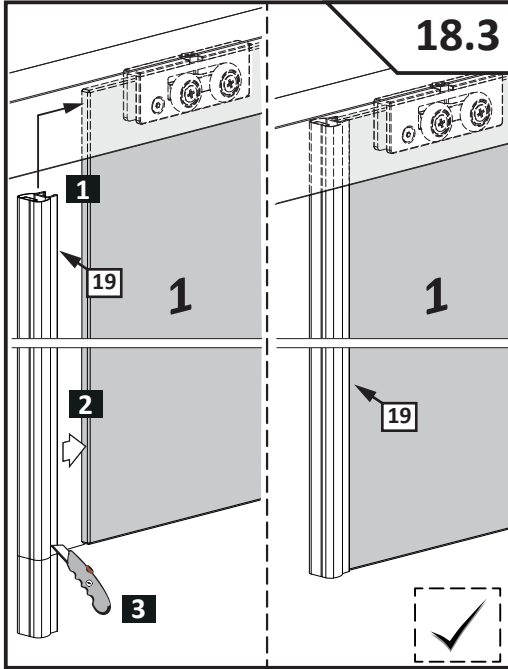

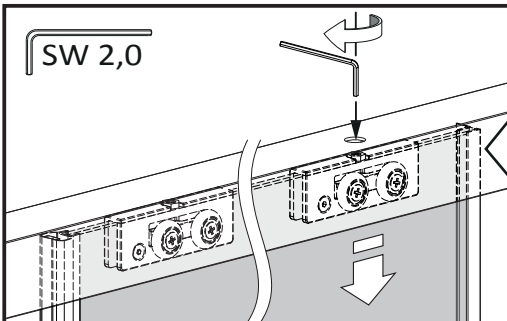
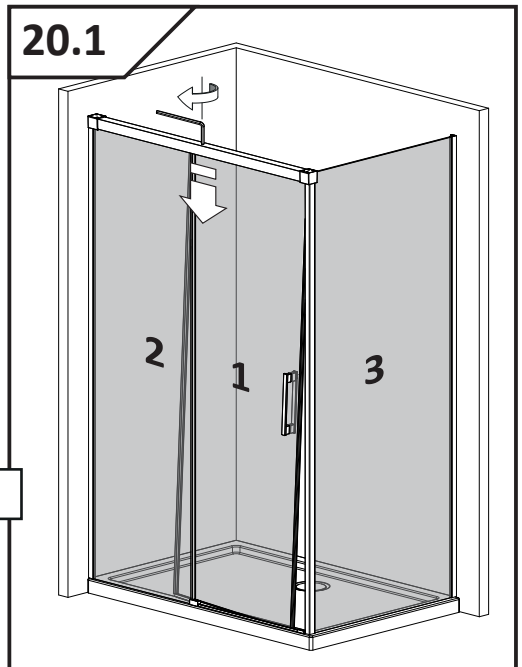
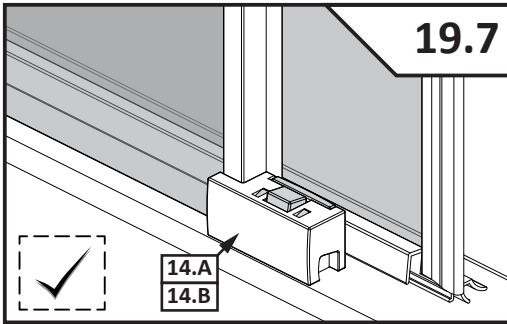
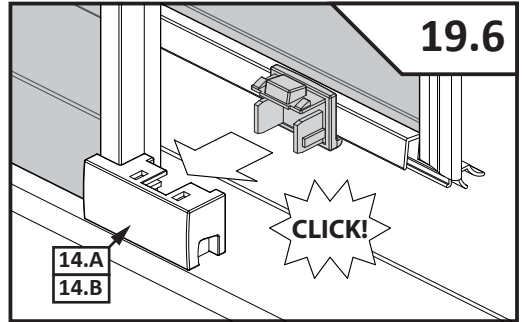
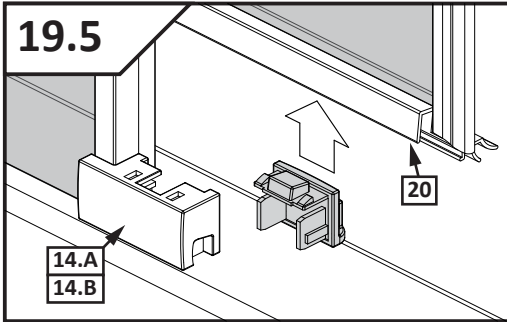
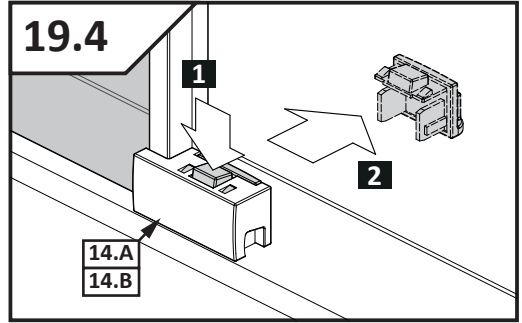
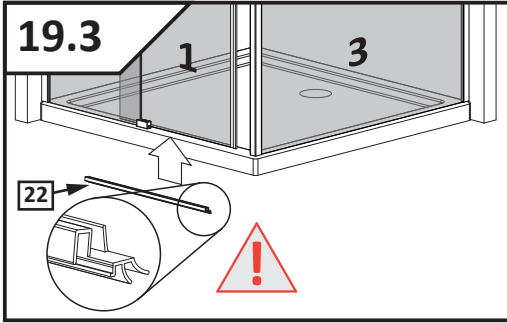

20.2

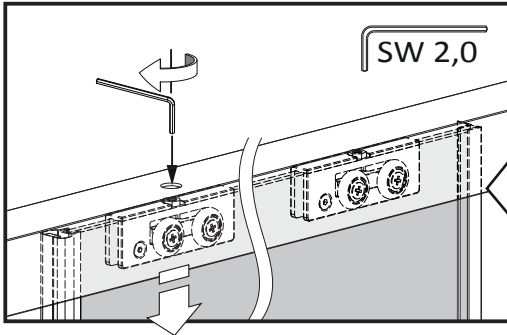
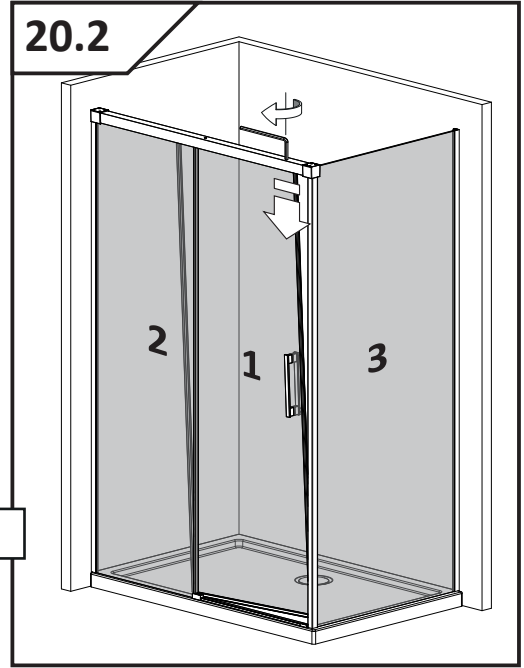

20.3

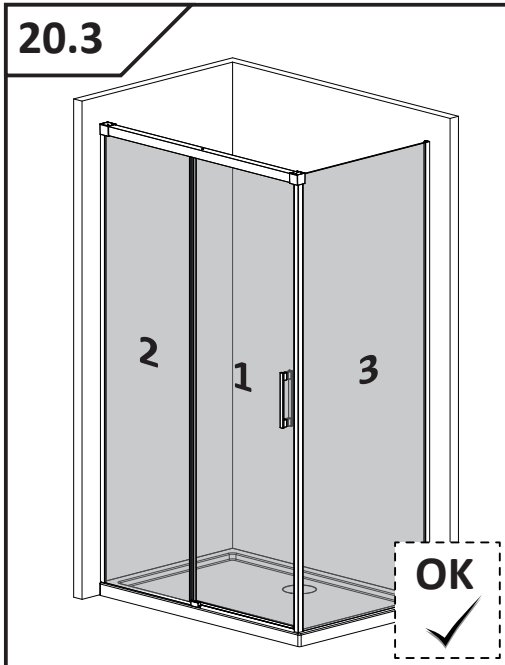

Montaż z listwą progową
Installation with threshold profile
Die Montage mit Schwalleiste
Montovanie s prahovým profilom
Instalace přechodové lišty
Монтаж с профилем порога
Szerelés küszöb profillal
Instalarea cu profil prag



21

Montaż bez listwy progowej
Installation without threshold profile
Die Montage ohne Schwalleiste
Montovanie bez prahového profilu
Instalace bez prahové lišty
Монтаж без профиля порога
Szerelés küszöb profil nélkül
Instalarea fara profil prag



22

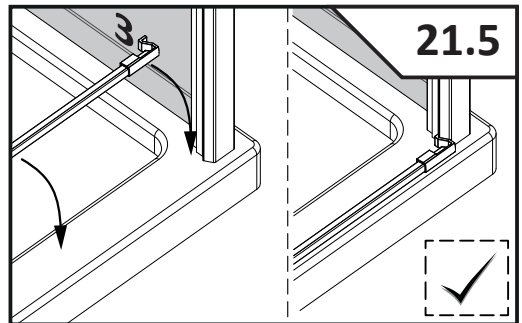
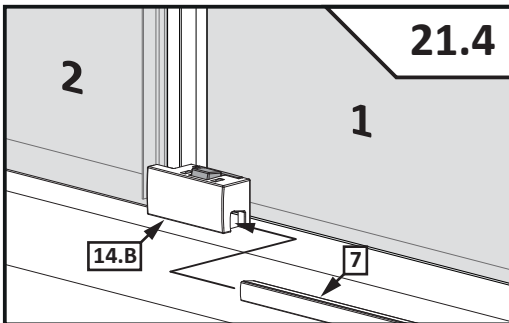
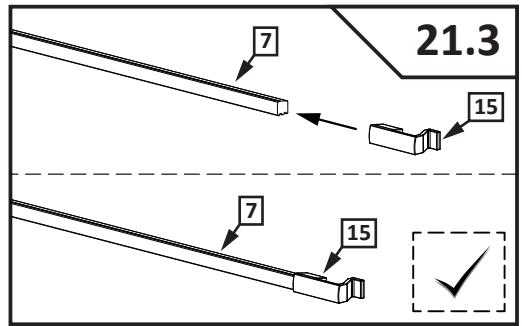
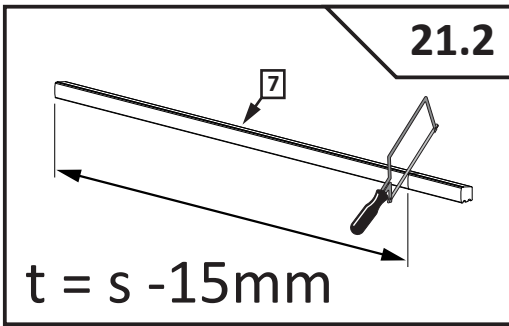
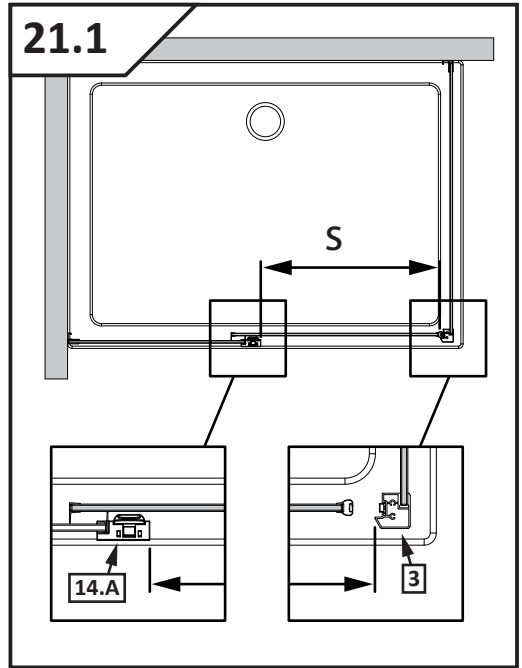
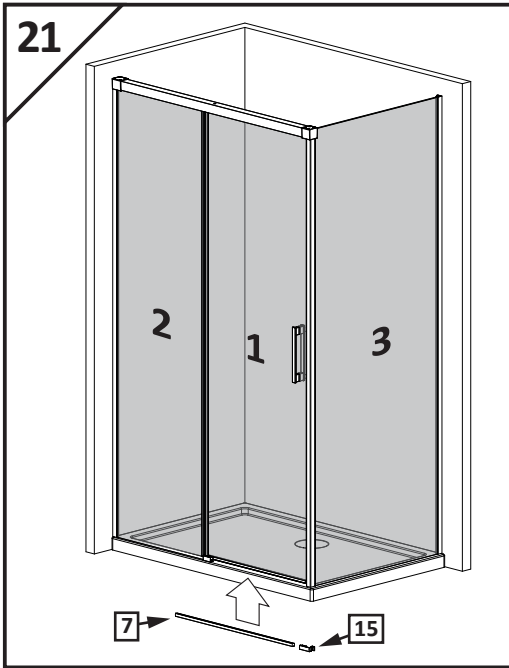

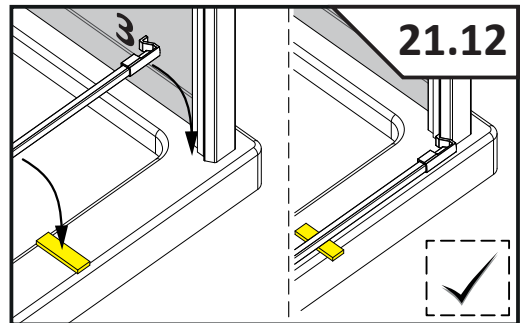
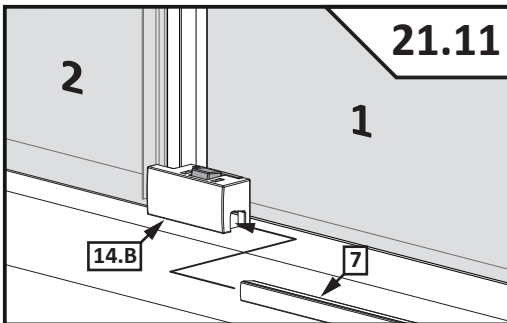
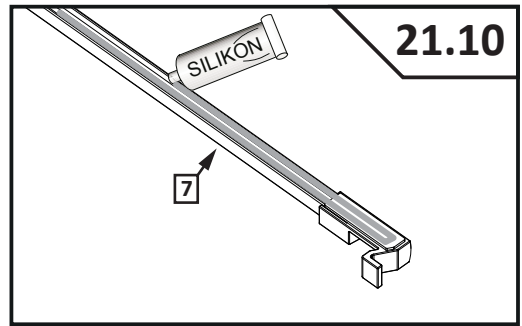
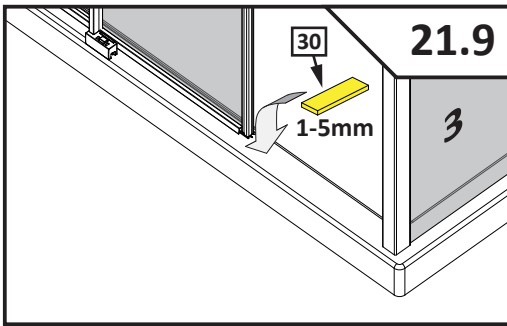
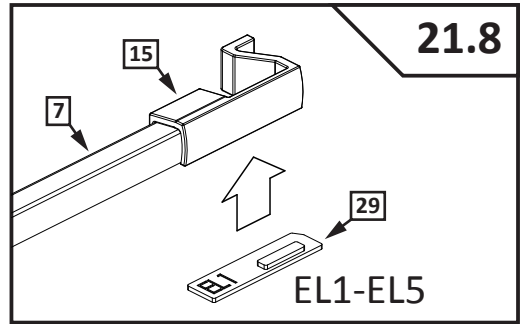
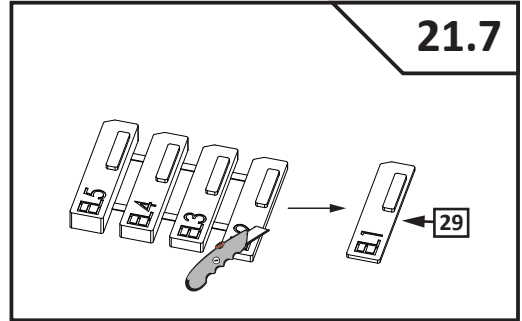
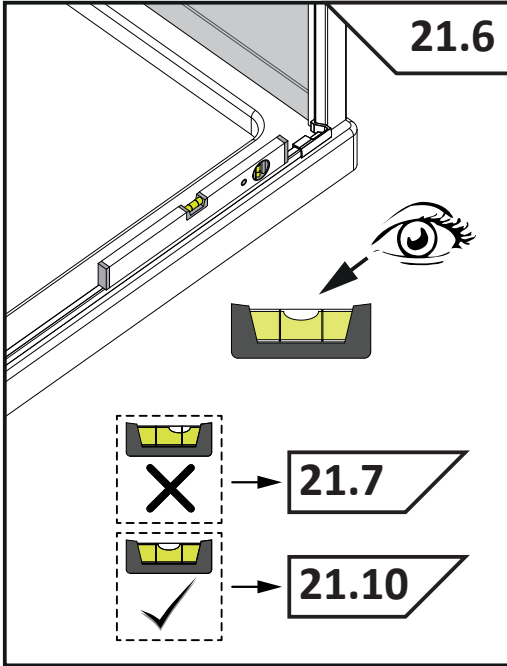

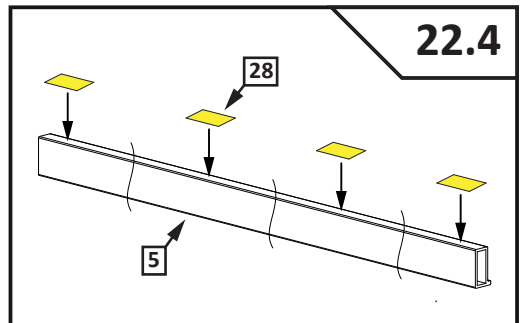
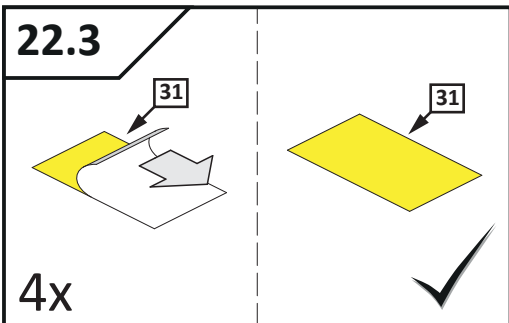
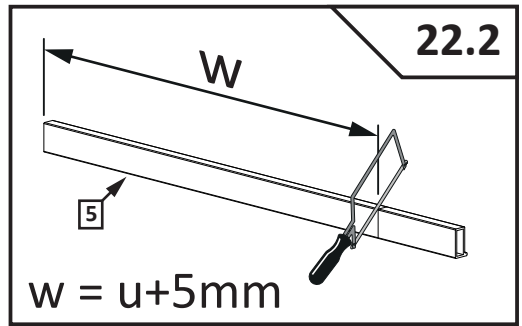
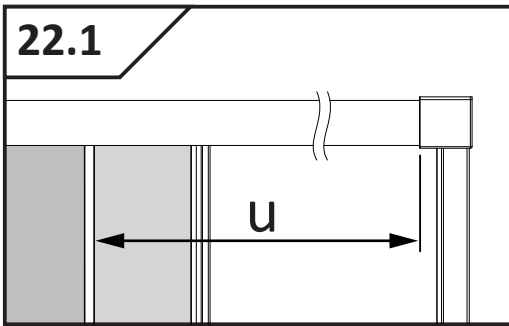
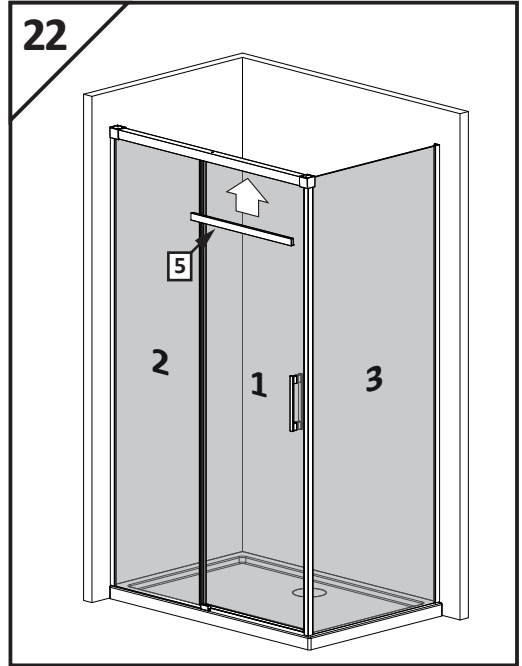
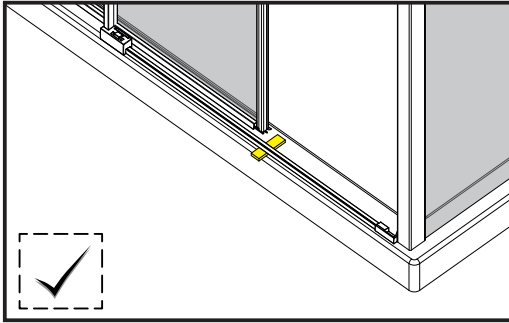

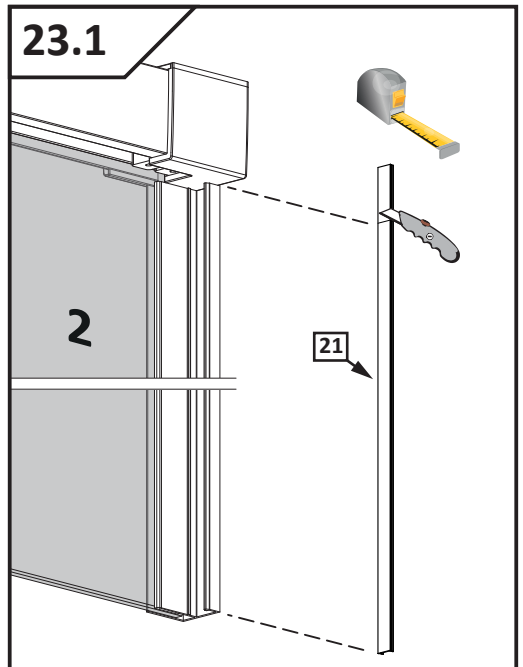
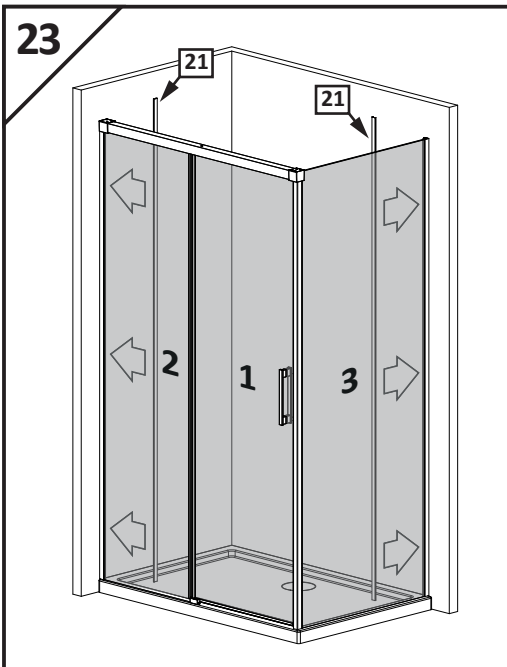
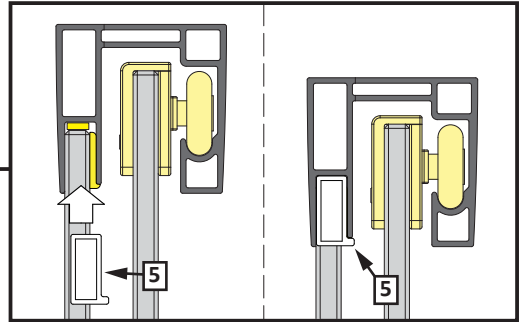
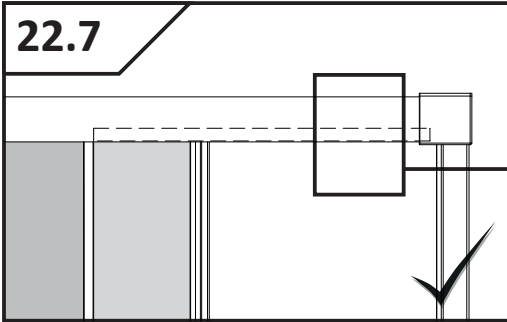
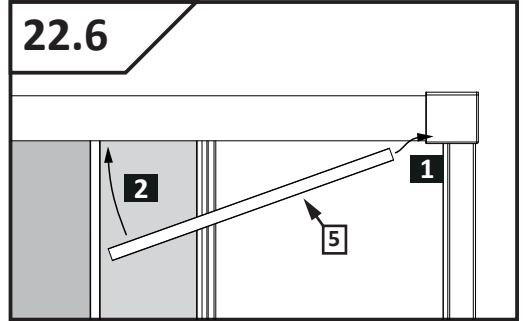
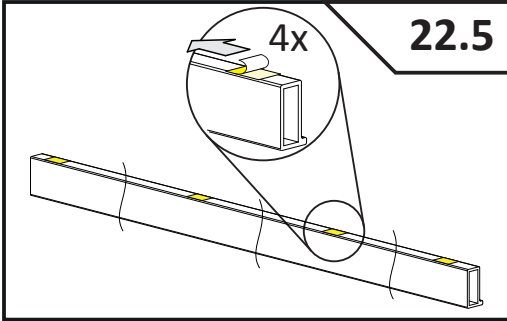

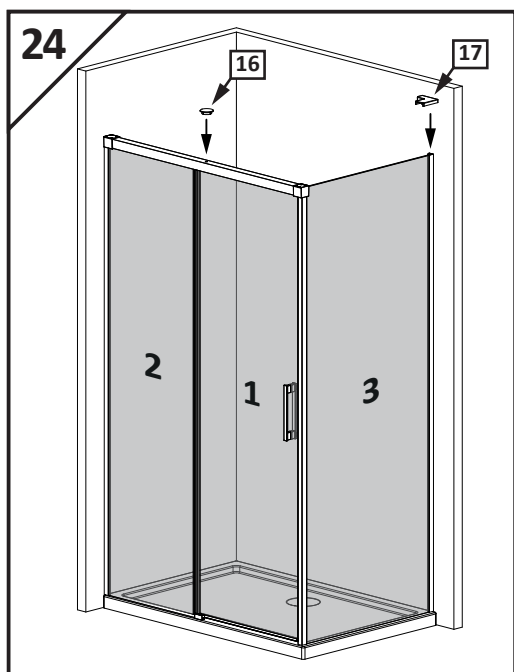
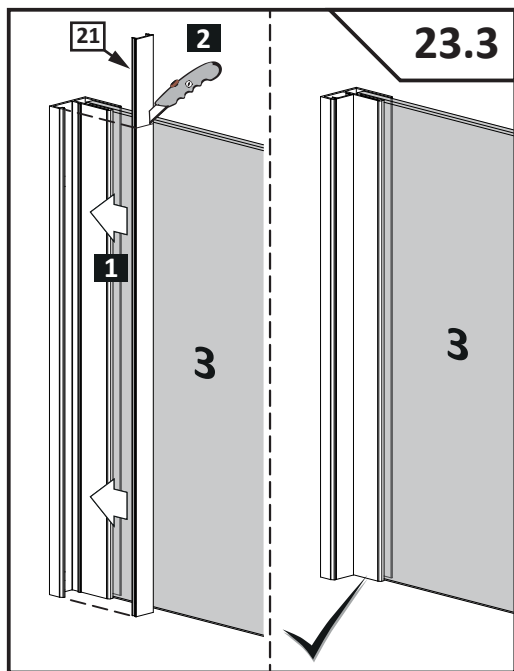
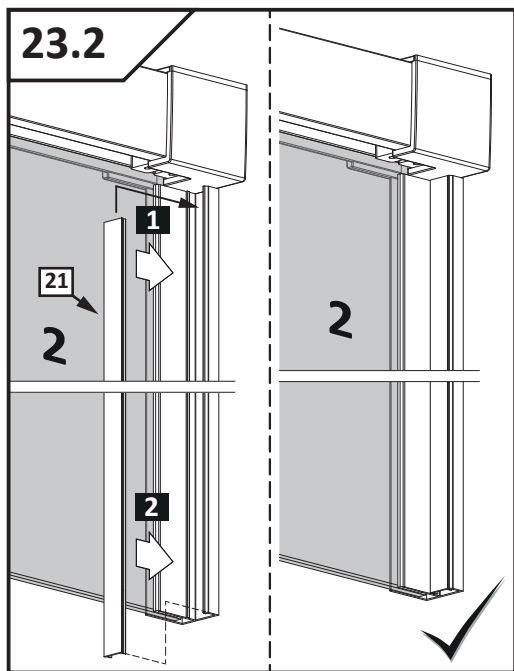

Montaż z listwą progową
 Installation with threshold profile
 Die Montage mit Schwalleiste
 Montovanie s prahovým profilom
 Instalace přechodové lišty
 Монтаж с профилем порога
 Szerelés küszöb profillal
 Instalarea cu profil prag

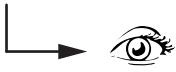

Montaż bez listwy progowej
 Installation without threshold profile
 Die Montage ohne Schwalleiste
 Montovanie bez prahového profilu
 Instalace bez prahové lišty
 Монтаж без профиля порога
 Szerelés küszöb profil nélkül
 Instalarea fara profil prag

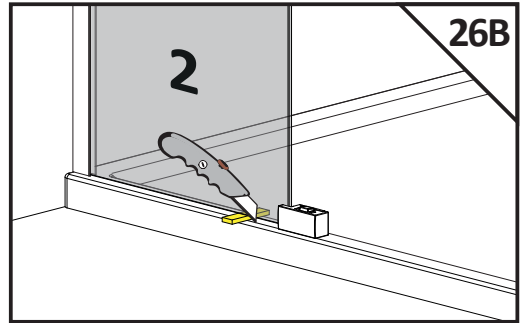
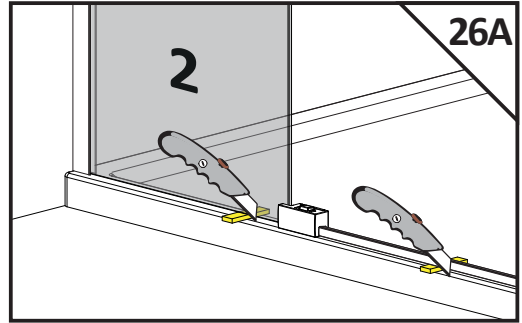
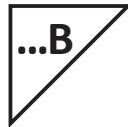

27A

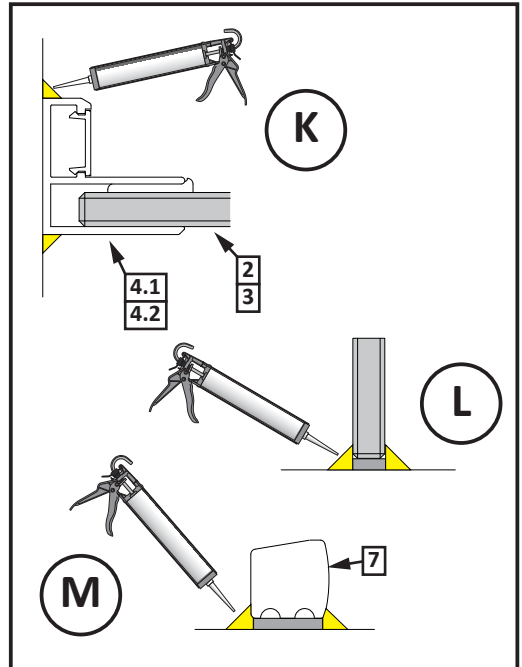
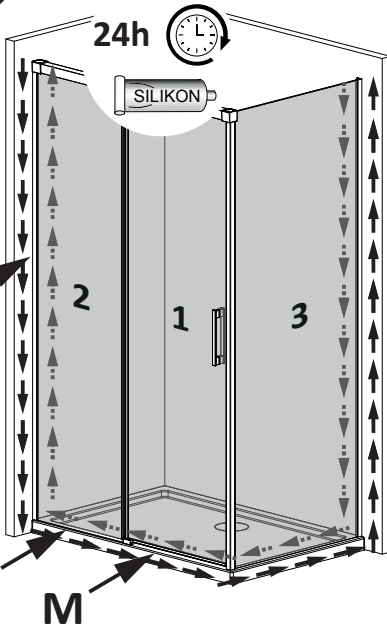

27B

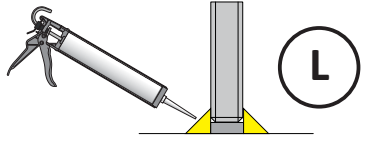
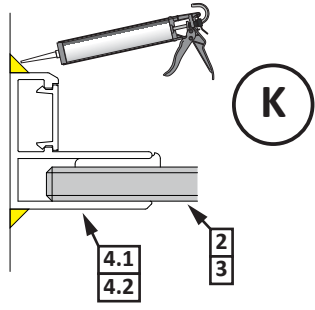
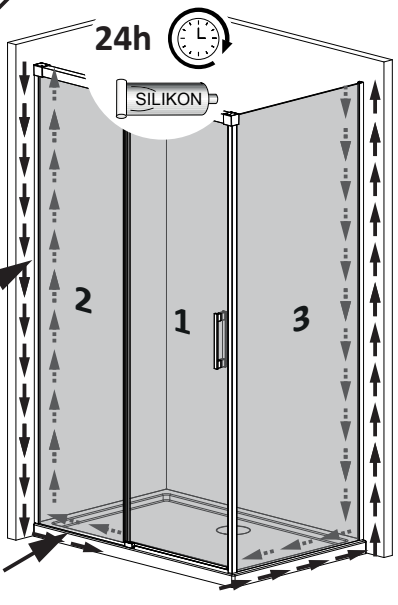

Návod na údržbu:



Na čistenie povrchu skla, plastové časti ako aj hliníkové profily je vhodné používať čistiace prostriedky a stierky doporučované výrobcom.

RADAWAY GLASS CLEANER čistiaci prostriedok na sprchovacie kúty a **RADAWAY GLASS PROTECTOR** na obnovenie povrchovej úpravy.

Údržba sprchovacích kútov

Doporučujeme aby sprchovací kút bol po každom použití očistený podľa nasledujúcich pokynov:

Vnútornú stranu kúta opláchnite čistou vodou a kvapky vody stiahnite gumennou stierkou. Chrómový povrch a lakované profily utrite do sucha mäkkou handričkou. Na údržbu povrchu skla, plastových častí a hliníkových profilov použite výrobky doporučené výrobcom.

Nepoužívajte riedidlá, acetón, kyselinu fosforovú, dezinfekčné prostriedky s obsahom chlóru. Ohľadne používania a ošetrovania sa informujte u svojho predajcu.

Dôkladná starostlivosť o výrobok

Ako často čistiť sprchovací kút? Údržbu prevádzame podľa toho, ako často sprchovací kút používame, aká je kvalita vody, buď raz týždenne alebo raz mesačne. Naneste na vnútornú stranu sprchovacieho kúta **RADAWAY GLASS CLEANER** čistiaci prostriedok. Miesta kde je väčšia vrstva usadeného vodného kameňa pretrite mäkkou handrou. V prípade potreby naneste **GLASS CLEANER** aj na handru.



Stierka **RADAWAY** z nehrdzavejúcej ocele pri pravidelnom používaní zabezpečí lesk a čistotu v sprchovacom kúte. Môžete ju použiť na obklad, sprchovací kút, sklo aj zrkadlo.

POZOR! A Glass Cleaner nenechajte pôsobyť dlhšie ako 10 min. Po pretretí povrchu čistiacim prostriedkom tento povrch opláchnite vodou. Kvapky vody odstráňte stierkou. Čistiaci prostriedok môžete použiť aj na vonkajšie povrchy sprchovacieho kúta. Chrómový povrch a lakované profily utrite do sucha mäkkou handrou. Doporučujeme ošetriť povrch skla **RADAWAY GLASS PROTECTOROM** na impregnáciu povrchu. Zabezpečte dôkladné vetranie miestnosti pre urýchlenie schnutia.

POZOR! Na údržbu chrómových častí sprchovacieho kúta používajte iba prípravky na báze kyseliny citrónovej. Nepoužívajte agresívne čistiace prostriedky, ktoré môžu spôsobiť značné škody na výrobkoch.